

# LAWS OF MOTION

## *Preface*

Newton's Laws of motion are of central importance in classical physics. To solve the problem in physics, mastery in this chapter is a must. Many phenomenon of our daily life can be explained by understanding them in the light of this chapter. This chapter needs a sound knowledge of vectors and kinematical equations. There are basically five forces (weight, normal force, frictional force, spring force, tension), which are commonly used in mechanics and you will be able to encounter the problems based on these forces after going through this chapter.

This book consists of theoretical & practical explanations of all the concepts involved in the chapter. Each article followed by a ladder of illustration. At the end of the theory part, there are miscellaneous solved examples which involve the application of multiple concepts of this chapter.

Students are advised to go through all these solved examples in order to develop better understanding of the chapter and to have better grasping level in the class.

Total number of Questions in <b>Laws of Motion</b> are :	
In Chapter Examples .....	36
Solved Examples .....	10
<b>Total no. of questions</b> .....	<b>46</b>

## 1. FIRST LAW OF MOTION ::

According to this law, every body continues in its state of rest or motion in a straight line unless it is compelled by external force to change that state.

- (i) This law is also called law of inertia. Inertia is a virtue by which a body opposes the state of rest or motion.
- (ii) Force is such a factor, which is essential for change in translatory motion of a body.
- (iii) The first law of motion defines the force.

**Ex. (a)** To remove the dust particles from a cloth by shaking it

- (b) Banking of the passengers (towards the motion of bus), sitting in a bus on applying the sudden brakes.

## 2. SECOND LAW OF MOTION ::

According to this law, the rate of change of momentum (mass  $\times$  velocity) of a body is proportional to the impressed force and it takes place in the direction of the force.

Mathematically  $\vec{F} \propto \frac{d\vec{p}}{dt}$

$$\Rightarrow \vec{F} = k \frac{d\vec{p}}{dt} = \frac{d\vec{p}}{dt}$$

(Defining force such a way that  $k = 1$ )

$$\vec{F} = \frac{d}{dt} (m \vec{v}) = m \frac{d\vec{v}}{dt}$$

$$\vec{F} = m \vec{a}$$

In scalar form,  $F = ma$

- (i) Force is a vector quantity, whose unit is

Newton or  $\frac{\text{Kg.m}}{\text{sec}^2}$  (In MKS)

and Dyne or  $\frac{\text{gm} \times \text{cm}}{\text{sec}^2}$  (In C. G. S.)

- (ii) The dimension of force is  $[\text{MLT}^{-2}]$
- (iii) The second law of motion gives the magnitude and unit of force.
- (iv) If  $m$  is not constant

$$\vec{F} = \frac{d}{dt} (m \vec{v}) = m \frac{d\vec{v}}{dt} + \vec{v} \frac{dm}{dt}$$

As in case of rocket propulsion, the mass of the fuel varies with respect to time.

## 3. THIRD LAW OF MOTION ::

According to this law, 'Every action has its equal and opposite reaction'

When two bodies A and B exert force on each other, the force (action) of A on B  $\left( \vec{F}_{BA} \right)$ , is always equal and opposite to the force of B on A  $\left( \vec{F}_{AB} \right)$

$$\text{Thus} \quad \vec{F}_{AB} = - \vec{F}_{BA}$$

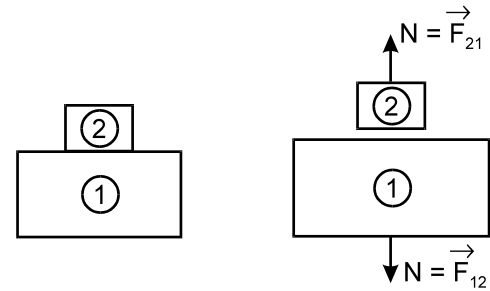

- (i) This law expresses the nature of force.
- (ii) Action and reaction always acts on different bodies

$$\vec{F}_{12} = - \vec{F}_{21}$$

### Impulse :

If a force acts on a body for a short duration  $\Delta t$ , then impulse is defined as product of force and its time of action

i.e. Impulse = Force  $\times$  Duration

$$\Rightarrow \Delta \vec{p} = \vec{F} \times \Delta t$$

By Newton's second law

$$\vec{F} = \frac{\Delta \vec{p}}{\Delta t}$$

$$\vec{F} \Delta t = \Delta \vec{p} = \vec{p}_f - \vec{p}_i$$

When  $\vec{p}_i$  and  $\vec{p}_f$  are initial and final momenta of the body respectively

$$\text{Thus impulse of force} = \vec{F} \Delta t = \Delta \vec{p} = \vec{p}_f - \vec{p}_i$$

Example based on

### Acceleration & Force Relation

**Ex.1** A body whose mass 6 kg is acted upon by two forces  $(8\hat{i} + 10\hat{j})\text{N}$  and  $(4\hat{i} + 8\hat{j})\text{N}$ . The acceleration produced will be - (in  $\text{m/s}^2$ )

- (A)  $(3\hat{i} + 2\hat{j})$                       (B)  $12\hat{i} + 18\hat{j}$   
 (C)  $\frac{1}{3}(\hat{i} + \hat{j})$                       (D)  $2\hat{i} + 3\hat{j}$

**Sol.(D)** Given that  $\vec{F}_1 = 8\hat{i} + 10\hat{j}$

and  $\vec{F}_2 = 4\hat{i} + 8\hat{j}$

Then the total force

$$\vec{F} = 12\hat{i} + 18\hat{j}$$

So acceleration

$$\begin{aligned} \vec{a} &= \frac{\vec{F}}{m} = \frac{12\hat{i} + 18\hat{j}}{6} \\ &= 2\hat{i} + 3\hat{j} \text{ m/sec}^2 \end{aligned}$$

Net acceleration

$$\begin{aligned} |\vec{a}| &= \sqrt{2^2 + 3^2} = \sqrt{4 + 9} \\ &= \sqrt{13} \text{ m/sec}^2 \end{aligned}$$

Hence correct answer is (D)

Example based on

### Second Law & Third Equation of Motion

**Ex.2** A car of 1000 kg moving with a velocity of 18 km/hr is stopped by the brake force of 1000 N. The distance covered by it before coming to rest is -

- (A) 1 m                                      (B) 162 m  
 (C) 12.5 m                                  (D) 144 m

**Sol.(C)** From the relation

$$F = ma$$

$$\Rightarrow a = \frac{F}{m} = \frac{1000}{1000} = 1 \text{ m/s}^2$$

As the force is brake force, acceleration is  $-1 \text{ m/s}^2$  using relation  $v^2 = u^2 + 2as$ , we obtain

$$\begin{aligned} 2as &= u^2 \\ \Rightarrow s &= \frac{u^2}{2a} = \frac{\left(18 \times \frac{5}{18}\right)^2}{2} = 12.5 \text{ m} \end{aligned}$$

Hence correct answer is (C)

Example based on

### Second Law of Motion

**Ex.3** A block of metal weighing 2 kg is resting on a frictionless plane. It is struck by a jet releasing water at a rate of 1 kg/s and at a speed of 5 m/s. The initial acceleration of the block will be

- (A)  $2.5 \text{ m/s}^2$                               (B)  $5 \text{ m/s}^2$   
 (C)  $0.4 \text{ m/s}^2$                               (D) 0

**Sol.(A)** The water jet striking the block at the rate of 1 kg/s at a speed of 5 m/s will exert a force on the block

$$F = v \frac{dm}{dt} = 5 \times 1 = 5 \text{ N}$$

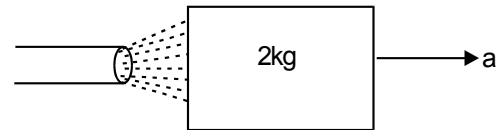

And under the action of this force of 5 N, the block of mass 2 kg will move with an acceleration given by,

$$F = ma$$

$$\Rightarrow a = F/m = 5/2 = 2.5 \text{ m/s}^2$$

Hence correct answer is (A)

Example based on

### Second Law of Motion or Relation of Change in Momentum

**Ex.4** A ball is moving with a velocity  $v$  strikes a wall moving towards the ball with velocity  $u$ . An elastic impact last for  $t$  sec. Then the mean elastic force acting on the ball is -

- (A)  $\frac{2m(v+u)}{t}$                                   (B)  $\frac{2m(v+2u)}{t}$   
 (C)  $\frac{m(2v+u)}{t}$                                   (D)  $\frac{m(2u+v)}{t}$

**Sol.(A)** Relative speed of the ball

$$= (v + u)$$

speed after rebounding

$$= -(v + u)$$

so,

$$\begin{aligned} F &= m \frac{\Delta v}{\Delta t} \\ &= \frac{m[(v+u) - \{-(v+u)\}]}{t} \\ &= \frac{2m(v+u)}{t} \end{aligned}$$

Hence correct answer is (A)

Example based on **Third Law of Motion**

**Ex.5** A man fires the bullets of mass  $m$  each with the velocity  $v$  with the help of machine gun, if he fires  $n$  bullets every sec, the reaction force per second on the man will be -

- (A)  $\frac{m}{v} n$                       (B)  $m n v$   
 (C)  $\frac{mv}{n}$                         (D)  $\frac{vn}{m}$

**Sol.(B)**  $F = \frac{dp}{dt}$   
 $\Rightarrow F dt = dp = p_2 - p_1$   
 $\Rightarrow F \times 1 = mnv - 0$   
 $\Rightarrow F = mnv$   
 (Total mass of the bullets fired in 1 sec =  $mn$ )  
 Hence correct answer is (B)

Example based on **Law of Action - Reaction**

**Ex.6** A body of mass 15 kg moving with a velocity of 10 m/s is to be stopped by a resistive force in 15 sec, the force will be -

- (A) 10 N                              (B) 5 N  
 (C) 100 N                            (D) 50 N

**Sol.(A)** The initial momentum  
 $= 15 \times 10 = 150 \text{ kgm/s}$   
 and force =  $\frac{\text{change in momentum}}{\text{time}}$   
 $= \frac{0 - 150}{15} = -10 \text{ N}$

A constant force of 10 N must be acting in opposite direction to the motion of body  
 Hence correct answer is (A)

Example based on **Relation between Force & Impulse**

**Ex.7** A cricket ball of mass 250 gm moving with velocity of 24 m/s is hit by a bat so that it acquires a velocity of 28 m/s in the opposite direction. The force acting on the ball, if the contact time is 1/100 of a second, will be -

- (A) 1300 N in the final direction of ball  
 (B) 13 N in the initial direction of ball  
 (C) 130 N in the final direction of ball  
 (D) 1.3 N in the initial direction of ball

**Sol.(A)** The change in momentum in the final direction is equal to the impulse

$$= \frac{2.50}{1000} \times 28 - \left( -\frac{250}{1000} \times 24 \right) = 13 \text{ Ns}$$

and force =  $\frac{\text{impulse}}{\text{time}} = \frac{13}{1/100} = 1300 \text{ N}$   
 in the direction of the ball.  
 Hence correct answer is (A)

Example based on **Relation Between Force & Momentum**

**Ex.8** A force of 2 N is applied on a particle for 2 sec, the change in momentum will be -

- (A) 2 Ns                              (B) 4 Ns  
 (C) 6 Ns                              (D) 3 Ns

**Sol.(C)** We know  $\vec{F} = \frac{d\vec{p}}{dt}$   
 $\Rightarrow \vec{F} dt = d\vec{p}$   
 $\Rightarrow 2 \times 2 = d\vec{p}$   
 $\Rightarrow 4 = d\vec{p}$

Therefore change in momentum = 4 Ns  
 Hence correct answer is (C)

Example based on **Change in Momentum**

**Ex.9** A body of mass 2 kg is moving along x-direction with velocity 2 m/sec. If a force of 4 N is applied on it along y-direction for 1 sec, the final velocity of particle will be -

- (A)  $2\sqrt{2}$  m/s                      (B)  $\sqrt{2}$  m/s  
 (C)  $1/\sqrt{2}$  m/s                      (D)  $1/2\sqrt{2}$  m/s

**Sol.(A)** We know  $\vec{F} = \frac{d\vec{p}}{dt}$   
 $\Rightarrow \vec{F} dt = d\vec{p} = \vec{p}_2 - \vec{p}_1$   
 $= m \vec{v}_2 - m \vec{v}_1$   
 $\Rightarrow 4 \hat{j} \cdot 1 = 2 \cdot \vec{v}_2 - 2(2\hat{i})$   
 $\Rightarrow 2\vec{v}_2 = 4\hat{j} + 4\hat{i}$   
 $\Rightarrow \vec{v}_2 = 2\hat{i} + 2\hat{j}$   
 $\Rightarrow |\vec{v}_2| = 2\sqrt{2} \text{ m/s}$   
 Hence correct answer is (A)

Example based on

## Calculation of Average Force

**Ex.10** A cricket ball of mass 150 g is moving with a velocity of 12 m/sec and is hit by a bat so that the ball is turned back with a velocity of 20 m/sec, the force on the ball acts for 0.01 sec, the average force exerted by the bat on the ball-

- (A) 48 N                      (B) 40 N  
(C) 480 N                    (D) 400 N

**Sol.(C)** Initial momentum of the ball

$$= \frac{150}{1000} \times 12 = 1.8 \text{ kg.m/sec}$$

Final momentum of the ball

$$= -\frac{150}{1000} \times 20 = -3.0 \text{ kg m/sec}$$

Change in momentum

$$= 4.8 \text{ kg m/sec}$$

Average force exerted

$$= \text{Impulse/ time} = \frac{4.8}{.01} \\ = 480 \text{ N}$$

Hence correct answer is (C)

Example based on

## Calculation of Impulse

**Ex.11** A body of mass 20 kg moving with a velocity of 3 m/s, rebounds on a wall with same velocity. The impulse on the body is -

- (A) 60 Ns                      (B) 120 Ns  
(C) 30 Ns                      (D) 180 Ns

**Sol.(B)** Initial momentum of the body

$$= mu = 20 \times 3 = 60$$

and final momentum of the body

$$= -mu = -20 \times 3 = -60$$

The change in momentum of body in initial direction =  $-60 - 60 = -120$

The change in momentum imparted to the body in opposite direction = 120

$\therefore$  The impulse imparted to the body = 120 Ns

Hence correct answer is (B)

## 4. REFERENCE FRAMES ::

Wherever the observer is situated in space that is called the frame of reference. The reference frame is associated with a co-ordinate system and a clock to measure the position and of the events happening in space.

### Types of Reference Frames :

#### 4.1 Inertial Reference Frame

#### 4.2 Non-inertial Frame

#### 4.1 Inertial Reference Frame:

- A reference frame in which Newton's first law is valid is called an inertial reference frame.
- An Inertial frame is either at rest or moving with uniform velocity.
- Frame moving at constant velocity relative to a known inertial frame is also an inertial frame.
- In an Inertial frame an object subject to zero net force will stay at rest or move at constant velocity.
- If acceleration of a particle is zero in one inertial frame, it is zero in all inertial frames.
- Ideally, no inertial frame exists in the universe for practical purpose, a frame of reference may be considered as Inertial if its acceleration is negligible with respect to the acceleration of the object to be observed.

### Note :

- To measure the acceleration of a falling apple, earth can be considered as an inertial frame.
- On the contrary, to observe the motion of planets earth can not be considered as an inertial frame but for this purpose the Sun may be assumed an inertial frame.

#### 4.2 Non Inertial Frame :

- An accelerated frame of reference is called a non inertial frame. Objects in non inertial frames do not obey Newton's first Law.
- Pseudo Force** : Imaginary force which is recognised only by a non-Inertial observer to explain the physical situation according to Newton's Laws.
- Magnitude of pseudo force  $F_p$  is equal to the product of the mass  $m$  of the object and the acceleration  $a$  of the frame of reference.

- (iv) The direction of the force is opposite to the direction of acceleration.  $F_p = -ma$
- (v) Force is imaginary in the sense that it has no physical origin, that is, it is not caused by one of the basic interactions in nature. It does not exist in the action reaction pair.

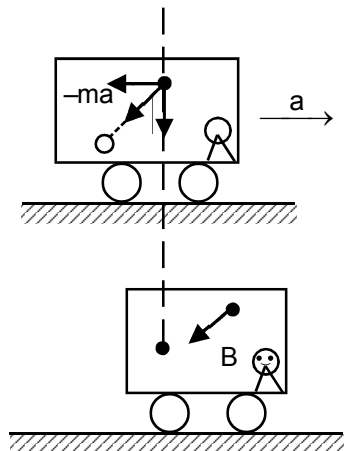
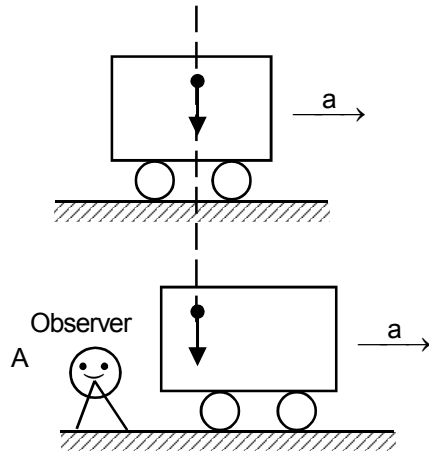

A ball is dropped inside a car which is initially at rest but has an acceleration  $a$  to the right.

(i) A stationary observer on the ground observes that the ball is falling vertically downwards with an acceleration $g$ (downwards)	(i) A person in the accelerated car observes that the ball moves down and towards the left of the car
(ii) Horizontally the ball does not move only the car moves to the right.	(ii) According to this observer, the backward acceleration of the ball is caused by the pseudo force.

**Ex.** A block of mass  $m$  rests on a smooth horizontal surface. It is being observed by two observers A and B ; observer A is stationary on the ground, observer B rides on a car moving towards right with an acceleration  $a$ . Draw the free body diagrams (F.B.D.) of the block as observed by A and B.

**Sol.**

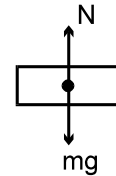

F.B.D of the block w.r.t. the observer A

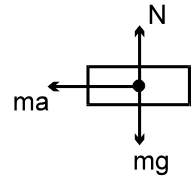

F.B.D. of the block w.r.t. the observer B

## 5. MOTION IN A LIFT ::

### Weight :

The pull of earth on any body under its gravitational influence is called the weight of the body. This force is directed towards the centre of the earth. This force produces an acceleration on the body called the acceleration due to gravity. If  $W$  is the weight of body of mass  $m$ , then

$$\vec{W} = m \vec{g} \text{ Newton}$$

### Note :

The weight of mass  $m$  of a body is also taken as  $m$  kilogram weight or  $m$  kilogram force or  $m$  kg weight =  $mg$  Newton

If a body is on an accelerated platform, the weight of the body appears changed and this new weight is called apparent weight. Let a man of weight

$$W = mg \text{ be standing in a lift.}$$

We consider the following cases.

### Case (A) :

**If the lift is unaccelerated ( $\vec{v} = 0$  or constant) :**

In this case there is reaction  $R = mg$

Hence apparent weight = actual weight

$$W' = \text{Actual weight} = mg$$

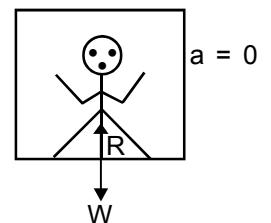

**Case (B):**

If the lift is accelerated upward

(when  $\vec{a} = \text{constant}$ ) :

The net forces acting on the man are

$$\therefore R - mg = ma$$

$\therefore$  Apparent weight

$$W' = R = mg + ma$$

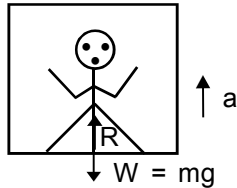

**Note :** Apparent weight ( $W'$ ) > Actual weight ( $mg$ )

**Case (C) :**

If the lift is accelerated downward :

Here the weight ' $mg$ ' acts downwards, while the reaction,

$R$  acts upward

Apparent weight  $W' = R$

$$\therefore mg - R = ma$$

$$\Rightarrow R = mg - ma$$

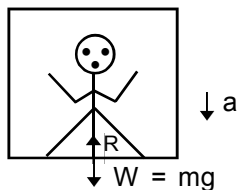

**Note :**

(i) Apparent weight  $W' <$  Actual weight  $W$

(ii) If  $g = a \Rightarrow W' = 0$

Thus in a freely falling lift, the man will experience a state of weightlessness

**Case (D) :**

If the lift is accelerated downwards such that  $a > g$  :

In this case  $ma$  is greater than the weight ( $mg$ )

$\therefore$  Apparent weight  $W' = m(g - a) = \text{negative}$

There is no meaning of negative apparent weight, therefore will be zero.

So the man will be accelerated upward and will stay at the ceiling of the lift.

Example based on

**Reaction Force**

**Ex.12** A man of mass 60 kg carries a bag of weight 60 N on his shoulder. The force with which the floor pushes up his feet will be -

- (A) 588 N                      (B) 648 N  
(C) 528 N                      (D) 708 N

**Sol.(B)** Weight of the man

$$= 60 \times 9.8 = 588 \text{ N}$$

Total force on the ground is

$$= 588 + 60 = 648 \text{ N}$$

$\therefore$  The floor pushes the feet with a force = 648 N

Hence correct answer is (B)

Example based on

**Comparison between Uniform Motion & Accelerated Motion of Lift**

**Ex.13** A spring weighing machine inside a stationary lift reads 50 kg when a man stand on it. What would happen to the scale reading if the lift is moving upward with (i) constant velocity (ii) constant acceleration -

(A) 50 kg wt,  $\left(50 + \frac{50a}{g}\right)$  kg wt

(B) 50 kg wt,  $\left(50 + \frac{50g}{a}\right)$  kg wt

(C) 50 kg wt,  $\left(\frac{50a}{g}\right)$  kg wt

(D) 50 kg wt,  $\left(\frac{50g}{a}\right)$  kg wt

**Sol.(A)**

(i) in the case of constant velocity of lift, there is no reaction, therefore the apparent weight = actual weight. Hence the reading of machine is 50 kg wt.

(ii) In this case the acceleration is upward the reaction  $R = ma$  acts downward, therefore apparent weight is more than actual weight . i.e.  $W' = W + R = m(g + a)$

Hence, scale show a reading of

$$m(g + a) \text{ Newton} = \left(50 + \frac{50a}{g}\right) \text{ kg wt}$$

Hence correct answer is (A)

Examples based on

**When Lift Moves Upward With Acceleration**

**Ex.14** A 25 kg lift is supported by a cable. The acceleration of the lift when the tension in the cable is 175 N, will be -

- (A)  $-2.8 \text{ m/s}^2$                       (B)  $16.8 \text{ m/s}^2$   
(C)  $-9.8 \text{ m/s}^2$                       (D)  $14 \text{ m/s}^2$

**Sol.(A)** Tension =  $m(g + a)$ , when lift moving up, putting the values, we get

$$175 = 25(9.8 + a)$$

$$\Rightarrow a = 2.8 \text{ m/s}^2$$

[negative sign shows that lift is moving downward]

Hence correct answer is (A)

**Ex.15** A body is suspended by a string from the ceiling of an elevator. It is observed that the tension in the string is doubled when the elevator is accelerated. The acceleration will be -

- (A)  $4.9 \text{ m/s}^2$                       (B)  $9.8 \text{ m/s}^2$   
 (C)  $19.6 \text{ m/s}^2$                       (D)  $2.45 \text{ m/s}^2$

**Sol.(B)** Apparent tension,

$$T = 2T_0$$

So  $T = 2T_0 = T_0 \left(1 + \frac{a_0}{g}\right)$

or  $2 = 1 + \frac{a_0}{g}$

$\Rightarrow a_0 = g = 9.8 \text{ m/s}^2$

Hence correct answer is (B)

**Example based on** **When Balloon Moves Upward With Acceleration**

**Ex.16** A balloon of mass  $m$  is rising up with an acceleration  $a$ . The fraction of weight that must be detached from the balloon, in order to double its acceleration will be (assuming the air upthrust remain the same) -

- (A)  $\frac{ma}{a+g}$                       (B)  $\frac{m}{a+g}$   
 (C)  $\frac{ma}{2a+g}$                       (D)  $\frac{2ma}{a+g}$

**Sol.(C)** Let  $R$  be the upthrust of the air.

The balloon rises with an acceleration of  $a$ .

Then  $R - mg = ma$  .....(1)

In the second case let a mass  $m_1$  be detached from the balloon so that the acceleration becomes  $2a$ .

Now  $R - (m - m_1)g = (m - m_1)2a$  ....(2)

From (1) & (2) equating & solving,

we get  $m_1 = \frac{ma}{g+2a}$

$\therefore$  The mass to be detached from the

balloon will be  $\frac{ma}{g+2a}$

Hence correct answer is (C)

**Example based on** **When Lift Moves Downward Under Different Conditions**

**Ex.17** A mass of  $60 \text{ kg}$  is on the floor of a lift moving down. The lift moves at first with an acceleration of  $3 \text{ m/sec}^2$ , then with constant velocity and finally with a retardation of  $3 \text{ m/sec}^2$ . The reactions exerted by the lift on the body in each part of the motion are respectively

- (A)  $408 \text{ N}, 580 \text{ N}, 768 \text{ N}$   
 (B)  $408 \text{ N}, 768 \text{ N}, 588 \text{ N}$   
 (C)  $408 \text{ N}, 588 \text{ N}, 768 \text{ N}$   
 (D)  $768 \text{ N}, 408 \text{ N}, 588 \text{ N}$

**Sol.(C)**

- (i) Since the lift is moving down with an acceleration of  $3 \text{ m/sec}^2$ , then the inertial force  $F = ma$ , acts upwards on the body

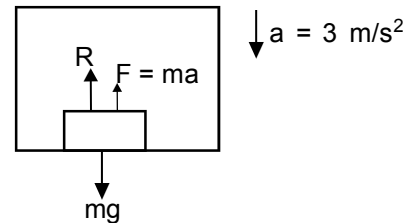

Now,  $R + F = mg$

or  $R = mg - F = mg - ma$   
 $= m(g - a)$   
 $= 60(9.8 - 3) = 408 \text{ N}$

- (ii) When the lift is moving down with constant velocity  $a = 0$

and hence,  $R = mg = 60 \times 9.8 = 588 \text{ N}$

- (iii) The lift is now moving down with a retardation of  $3 \text{ m/sec}^2$ .

The retardation is  $3 \text{ m/sec}^2$  in the downward direction is equivalent to an acceleration of  $3 \text{ m/sec}^2$  upwards.

Hence the direction of fictitious force is downwards.

Now  $R = mg + ma = m(g + a)$   
 $= 60(12.8) = 768 \text{ N}$

Hence correct answer is (C)

Example based on

## Comparison between Upward & Downward Motion of Lift With Acceleration

- Ex.18** A mass of 10 kg is hung to a spring balance in lift. If the lift is moving with an acceleration  $g/3$  in upward & downward directions. The reading will respectively be  
 (A) 6.67 kg, 13.3 kg (B) 13.3 kg, 6.67 kg  
 (C) 32.6 kg, 0 (D) 13.3 kg, 0

**Sol.(B)** When the lift is moving up  $m(g + a) = \text{force}$

$$\begin{aligned} \text{The scale reading} &= \frac{m(g+a)}{g} = \frac{10\left(g + \frac{g}{3}\right)}{g} \\ &= 13.3 \text{ kg} \end{aligned}$$

When lift is moving down the scale reading

$$\begin{aligned} &= \frac{m(g-a)}{g} = \frac{10\left(g - \frac{g}{3}\right)}{g} \\ &= 6.67 \text{ kg} \end{aligned}$$

Hence correct answer is (B)

## 6. MOTION OF A BLOCK ON A HORIZONTAL SMOOTH SURFACE ::

**Case (A) :**

**When subjected to a horizontal pull :**

The distribution of forces on the body are shown.

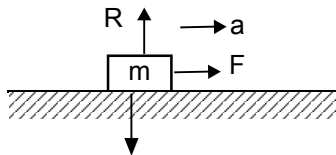

As there is no motion along vertical direction, hence,  $R = mg$

For horizontal motion  $F = ma$  or  $a = F/m$

**Case (B) :**

**When subjected to a pull acting at an angle ( $\theta$ ) to the horizontal :**

Now  $F$  has to be resolved into two components,

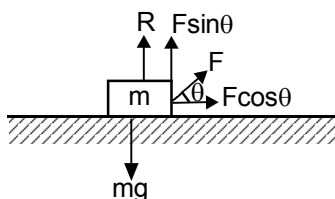

$F \cos \theta$  along the horizontal and  $F \sin \theta$  along the vertical direction.

For no motion along the vertical direction, we have  $R + F \sin \theta = mg$

or  $R = mg - F \sin \theta$

**Note:**

Hence  $R \neq mg$  .  $R < mg$

For horizontal motion

$$F \cos \theta = ma, \quad a = \frac{F \cos \theta}{m}$$

**Case(C) :**

**When the block is subjected to a push acting at an angle  $\theta$  to the horizontal : (downward)**

The force equation in this case

$$R = mg + F \sin \theta$$

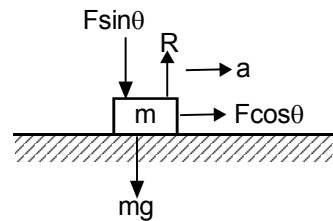
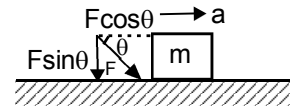

**Note :**  $R \neq mg$ ,  $R > mg$

For horizontal motion

$$\begin{aligned} F \cos \theta &= ma, \\ a &= \frac{F \cos \theta}{m} \end{aligned}$$

Example based on

## Motion of Block on Smooth Plane in Presence of Horizontal Force

- Ex.19** A block of mass  $M$  is pulled along a horizontal frictionless surface by a rope of mass  $m$  . If a force  $P$  is applied at the free end of the rope. The force exerted by the rope on the block will be -

- (A)  $P$  (B)  $\frac{Pm}{M+m}$   
 (C)  $\frac{MP}{M+m}$  (D)  $\frac{mP}{M+m}$

**Sol.(C)** Force on the block

= Mass of the block  $\times$  acceleration of the system =  $M \times \frac{P}{M+m}$

Hence correct answer is (C)

**Ex.20** A body of mass 50 kg is pulled by a rope of length 8 m on a surface by a force of 108N applied at the other end. The force that is acting on 50 kg mass, if the linear density of rope is 0.5 kg/m will be -

- (A) 108 N (B) 100 N  
(C) 116 N (D) 92 N

**Sol.(B)** Mass of the rope =  $8 \times \frac{1}{2} = 4$  kg

Total mass =  $50 + 4 = 54$  kg

$$\therefore a = \frac{F}{m} = \frac{108}{54} = 2 \text{ m/s}^2$$

Force utilised in pulling the rope =  $4 \times 2 = 8$  N

Force applied on mass =  $108 - 8 = 100$  N

Hence correct answer is (B)

**Ex.21** A rope of length 15 m and linear density 2 kg/m is lying length wise on a horizontal smooth table. It is pulled by a force of 25 N. The tension in the rope at the point 7 m away from the point of application, will be -

- (A) 11.67 N (B) 13.33 N  
(C) 36.67 N (D) None of these

**Sol.(B)** Mass of the rope =  $15 \times 2 = 30$  kg

$$\text{acceleration} = \frac{F}{m} = \frac{25}{30} = \frac{5}{6} \text{ m/s}^2$$

At the point 7 m away from point of application the mass of first part of rope = 14 kg

$\therefore$  Force used in pulling 14 kg

$$= 14 \times \frac{5}{6} = 11.67 \text{ N}$$

The remaining force =  $(25 - 11.67) \text{ N} = 13.33 \text{ N}$

Hence correct answer is (B)

Example based on

### Motion of Block on Horizontal Smooth Plane When Force Making Angle with Horizontal Direction

**Ex.22** A force of 100 N acts, in the direction as shown in figure on a block of mass 10 kg

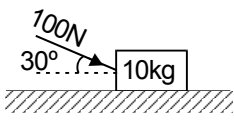

resting on a smooth horizontal table. The speed acquired by the block after it has moved a distance of 10 m, will be -

- (in m/sec) ( $g = 10 \text{ m/sec}^2$ )  
(A) 17 m/sec (B) 13.17 m/sec  
(C) 1.3 m/sec (D) 1.7 m/sec

**Sol.(B)** The various forces acting are shown in fig.

The force of 100N has

(i) horizontal component of

$$100 \cos 30^\circ = 50\sqrt{3} \text{ N} \quad \text{and}$$

(ii) A vertical component =  $100 \sin 30^\circ = 50 \text{ N}$

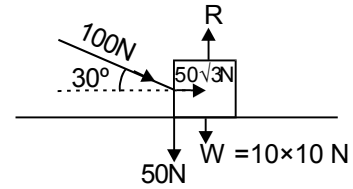

Since the block is always in contact with the table, the net vertical force

$$R = mg + F \sin \theta = (10 \times 10 + 50) \text{ N} = 150 \text{ N}$$

When the block moves along the table, work is done by the horizontal component of the force. Since the distance moves is 10 m, the

work done is =  $50\sqrt{3} \times 10 = 500\sqrt{3}$  Joule.

If  $v$  is the speed acquired by the block, the work done must be equal to the kinetic energy of the block. Therefore, we have

$$500\sqrt{3} = \frac{1}{2} \times 10 \times v^2 \Rightarrow v^2 = 100\sqrt{3}$$

$$\Rightarrow v = 13.17 \text{ m/sec}$$

Hence correct answer is (B)

**Ex.23** In the above example, the velocity after 2 sec will be - (in m/sec)

- (A)  $10\sqrt{3}$  (B)  $5\sqrt{3}$   
(C) 10 (D) 5

**Sol.** We have acceleration  $a = \frac{F \cos \theta}{m} = \frac{50\sqrt{3}}{10}$

$$= 5\sqrt{3} \text{ m/sec}^2$$

The velocity after 2 sec,  $v = u + at$

$$\Rightarrow v = 0 + 5\sqrt{3} \times 2 = 10\sqrt{3} \text{ m/sec}$$

Hence correct answer is (A)

## 7. MOTION OF BODIES IN CONTACT ::

**Case (A) :**

**Two body system :**

Let a force  $F$  be applied on mass  $m_1$ .

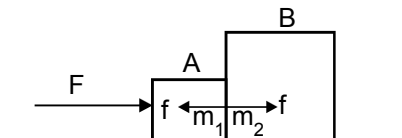

**Free body diagrams:** (vertical force do not cause motion, hence they have not been shown in diagram)

For A	For B
$F - f = m_1 a$	$f = m_2 a$

$$\Rightarrow a = \frac{F}{m_1 + m_2}$$

$$\text{and } f = \frac{m_2 F}{m_1 + m_2}$$

(i) Here  $f$  is known as force of contact.

(ii) Acceleration of system can be found simply by

$$a = \frac{\text{force}}{\text{total mass}}$$

**Note:**

If force  $F$  be applied on  $m_2$ , the acceleration will remain the same, but force of contact

will be different i.e.  $f' = \frac{m_1 F}{m_1 + m_2}$

**Case (B) :**

**Three body system :**

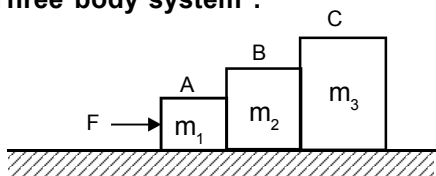

**Free body diagrams :**

For A	For B	For C
$F - f_1 = m_1 a$	$f_1 - f_2 = m_2 a$	$f_2 = m_3 a$

$$\Rightarrow a = \frac{F}{m_1 + m_2 + m_3}$$

$$\text{and } f_1 = \frac{(m_2 + m_3)F}{(m_1 + m_2 + m_3)}$$

$$f_2 = \frac{m_3 F}{(m_1 + m_2 + m_3)}$$

$f_1$  = contact force between masses  $m_1$  and  $m_2$

$f_2$  = contact force between masses  $m_2$  and  $m_3$

**Remember :**

Contact force is different if force  $F$  will be applied on mass C

**Example based on Tangential Force When Two Blocks are in Contact**

**Ex.24** Two blocks of mass  $m = 1$  kg and  $M = 2$  kg are in contact on a frictionless table. A horizontal force  $F (= 3\text{N})$  is applied to  $m$ . The force of contact between the blocks, will be-

- (A) 2 N
- (B) 1 N
- (C) 4 N
- (D) 5 N

**Sol.(A)** All the forces acting on the two blocks are shown in fig. As the blocks are rigid under the action of a force  $F$ , both will move together with same acceleration.

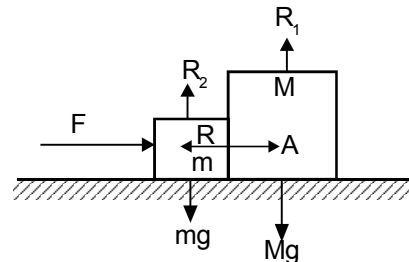

$$a = F/(m+M) = 3/(1+2) = 1 \text{ m/s}^2$$

Now as the mass of larger block is  $m$  and its acceleration  $a$  so force of contact i.e. action on it.

$$f = Ma = \frac{MF}{M+m} = \frac{2 \times 3}{2+1} = 2\text{N}$$

Hence correct answer is (A)

**Note:** If the force is applied to  $M$ , its action on  $m$  will be

$$f' = ma = \frac{mF}{M+m} = \frac{1 \times 3}{2+1} = 1 \text{ N}$$

**Example based on Acceleration of System When Two Blocks are in Contact**

**Ex.25** A force produces an acceleration of  $5 \text{ m/s}^2$  in a body and same force an acceleration of  $15 \text{ m/s}^2$  in another body. The acceleration produced by the same force when applied to the combination of two bodies will be -

- (A)  $3.75 \text{ m/s}^2$
- (B)  $20 \text{ m/s}^2$
- (C)  $10 \text{ m/s}^2$
- (D)  $0.667 \text{ m/s}^2$

**Sol.(A)** As the same force is applied to the combined mass, we have

$$\frac{1}{a} = \frac{1}{a_1} + \frac{1}{a_2}$$

$$\begin{aligned} \text{or } a &= \frac{a_1 a_2}{a_1 + a_2} \\ &= \frac{5 \times 15}{5 + 15} = 3.75 \text{ m/s}^2 \end{aligned}$$

Hence correct answer is (A)

**Remember :**

If  $a_1, a_2, \dots, a_n$  be the accelerations produced in  $n$  different bodies on applying the same force, the acceleration produced in their combination due to the same force will be -

$$\frac{1}{a} = \frac{1}{a_1} + \frac{1}{a_2} + \dots + \frac{1}{a_n}$$

**Example based on Solving The Question by Assuming The System of Two Parts of a Block**

**Ex.26** What is the tension in a rod of length  $L$  and mass  $M$  at a distance  $y$  from  $F_1$  when the rod is acted on by two unequal forces  $F_1$  and  $F_2$  ( $<F_1$ ) as shown in fig

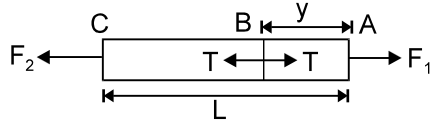

- (A)  $F_1 \left(1 - \frac{y}{L}\right) + F_2 \left(\frac{y}{L}\right)$  (B)  $\frac{M}{L} y \left(\frac{F_1 - F_2}{M}\right)$   
 (C)  $F_1 \left(1 + \frac{y}{L}\right) + F_2 \left(\frac{y}{L}\right)$  (D)  $\frac{M}{L} y \left(\frac{F_1 + F_2}{M}\right)$

**Sol.(A)** As net force on the rod =  $F_1 - F_2$  and its mass is  $M$  so acceleration of the rod will be

$$a = (F_1 - F_2)/M \quad \dots(i)$$

Now considering the motion of part AB of the rod, which has mass  $(M/L)y$ ,

Acceleration  $a$  given by

(i) Assuming that tension at B is  $T$

$$F_1 - T = \frac{M}{L} y \times a \quad (\text{from } F = ma)$$

$$\begin{aligned} \Rightarrow F_1 - T &= \frac{M}{L} y \frac{F_1 - F_2}{M} \\ & \quad (\text{using eq. (1)}) \end{aligned}$$

$$\Rightarrow T = F_1 \left(1 - \frac{y}{L}\right) + F_2 \left(\frac{y}{L}\right)$$

Hence correct answer is (A)

**Example based on Acceleration of system of n Blocks**

**Ex.27** A force produces acceleration

$1, \frac{1}{2}, \frac{1}{3}, \frac{1}{4}, \dots$  (all in  $\text{m/s}^2$ ), when applied separately to  $n$  bodies. If these bodies are combined to form single one, then the acceleration of the system will be, if same force is taken into account -

- (A)  $\frac{n}{2}$  (B)  $\frac{2}{n(n+1)}$   
 (C)  $\frac{n^2}{2}$  (D)  $\frac{n^2(n+1)}{2}$

**Sol.(B)** The net acceleration of the system is given by

$$\begin{aligned} \frac{1}{a} &= \frac{1}{a_1} + \frac{1}{a_2} + \dots + \frac{1}{a_n} \\ &= 1 + 2 + 3 + \dots + n \\ &= \frac{n}{2} [2 + (n - 1) 1] \\ &= \frac{n}{2} [n + 1] = \frac{2}{n(n+1)} \end{aligned}$$

**8. MOTION OF CONNECTED BODIES ::**

**Case (A) :**

**For Two Bodies :**

$F$  is the pull on body A of mass  $m_1$ . The pull of A on B is exercised as tension through the string connecting A and B. The value of tension throughout the string is  $T$  only.

But this manifests as a pull  $T$  on B and a "reaction pull"  $T$  on A the free body diagram in this case are shown as follows.

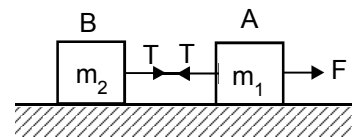

**Note :** The spring is massless

**Free body diagrams :**

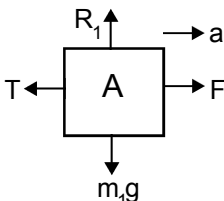
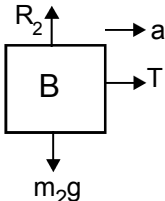
For body A	For body B
	
$R_1 = m_1 g$ $F - T = m_1 a$	$R_2 = m_2 g$ $T = m_2 a$

$$\Rightarrow a = \frac{F}{m_1 + m_2}$$

Case (B) :

For Three bodies :

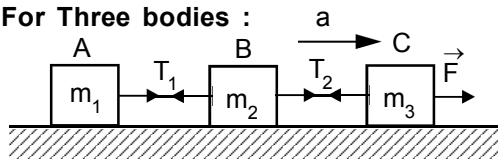

Free body diagrams :

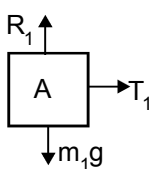
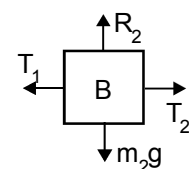
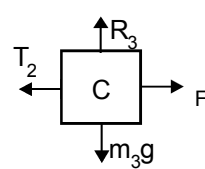
For A	For B	For C
		
$R_1 = m_1 g$ $T_1 = m_1 a$	$R_2 = m_2 g$ $T_2 - T_1 = m_2 a$ $\Rightarrow T_2 = m_2 a + T_1$ $T_2 = (m_2 + m_1) a$	$R_3 = m_3 g$ $F - T_2 = m_3 a$ $\Rightarrow F = m_3 a + T_2$ $F = m_3 a + (m_1 + m_2) a$ $F = (m_1 + m_2 + m_3) a$

$$\Rightarrow a = F / (m_1 + m_2 + m_3)$$

**Example based on Calculation of Tension When Rope is not Massless**

**Ex.28** Two blocks of masses 6 kg and 4 kg connected by a rope of mass 2 kg are resting on frictionless floor as shown in fig. If a constant force of 60 N is applied to 6 kg block, tension in the rope at A, B, and C will respectively be -

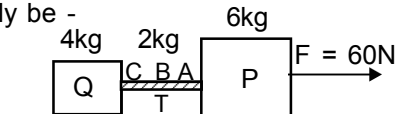

- (A) 30 N, 25 N, 20 N (B) 25 N, 30 N, 20 N  
 (C) 20 N, 30 N, 25 N (D) 30 N, 20 N, 25 N

**Sol.(A)** As the mass of the system is

6 + 4 + 2 = 12 kg and applied force is 60 N,

the acceleration of the system

$$a = \frac{F}{m} = \frac{60}{12} = 5 \text{ m/s}^2$$

Now at point A as tension in pulling the rope of mass 2kg and block Q of mass 4kg.

$$T_A = (2 + 4) \times 5 = 30\text{N}$$

Similarly for B and C,

$$T_B = (1 + 4) \times 5 = 25\text{N}$$

and

$$T_C = (0 + 4) \times 5 = 20\text{N}$$

Hence correct answer is (A).

**Note:** In this problem as rope is not massless tension is different at different points of the string being maximum at the end closest to the applied force and minimum at the end farthest from the force.

**9. MOTION OF A BODY ON A SMOOTH INCLINED PLANE ::**

A body is placed on a smooth inclined plane AB which makes an angle  $\theta$  with the horizontal. The forces acting on body are

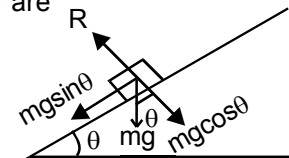

- (i) Weight of the body  $mg$  acting vertically down.
- (ii) Normal reaction  $R$  acting perpendicular to the plane.

The weight  $mg$  of the body is resolved parallel and perpendicular to the plane as  $mg \sin \theta$  parallel to the plane and  $mg \cos \theta$  perpendicular to the plane.

$$\text{Thus } ma = mg \sin \theta \Rightarrow a = g \sin \theta \quad \dots(i)$$

$$R = mg \cos \theta \quad \dots(ii)$$

**Note:**

The same result can also be obtained by resolving the forces horizontally and vertically.

$$R \sin \theta = ma \cos \theta$$

$$mg - R \cos \theta = ma \sin \theta$$

solving we get,

$$a = g \sin \theta, R = mg \cos \theta$$

**Special case :**

When the smooth plane is moving horizontally with an acceleration ( $b$ ) as shown in fig

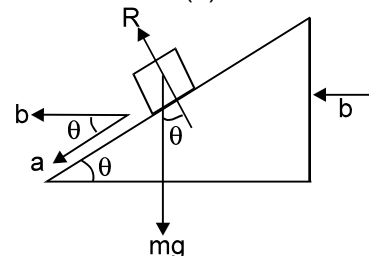

In this case :

$$m(a + b \cos \theta) = mg \sin \theta$$

$$\text{and } mb \sin \theta = R - mg \cos \theta$$

$$\text{solving we get } a = g \sin \theta - b \cos \theta$$

$$R = m(g \cos \theta + b \sin \theta)$$

## 10. MOTION OF TWO BODIES CONNECTED BY A STRING ::

**Case (A) :**

**Motion of unequal masses suspended from a light frictionless pulley:**

A and B are two bodies of mass  $m_1$  and  $m_2$  respectively suspended by means of a light string passing over a smooth pulley P.

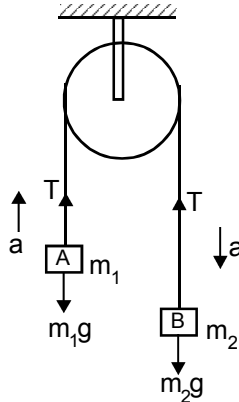

Let  $m_2 > m_1$ . If the string is light and continuous a tension  $T$  exists all along the string.

The forces acting on A and B are clearly shown. Let A moves up with an acceleration  $a$  and B move down with the same acceleration.

For the motion of A

$$T - m_1g = m_1a \quad \dots(i)$$

For the motion of B

$$m_2g - T = m_2a \quad \dots(ii)$$

$$\text{Solving, } a = \frac{(m_2 - m_1)}{(m_1 + m_2)}g \quad \text{and } T = \frac{2m_1m_2}{m_1 + m_2}g$$

**Case (B) :** Let us consider the case of a body of mass ( $m_1$ ), to which a light and string is attached rests on a smooth horizontal plane. The string passes over a frictionless pulley fixed at the end of plane. Another end of the string carries a mass ( $m_2$ ) as shown in fig. Our aim is to calculate the acceleration of the system and tension in the string :

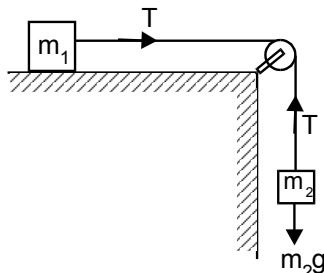

Here We have

$$(m_2g - T) = m_2a \quad \dots(1)$$

$$\text{and } T = m_1a \quad \dots(2)$$

Solving these equations we have,

$$a = \left[ \frac{m_2}{(m_1 + m_2)} \right]g \quad \text{and}$$

$$T = m_1a = \left[ \frac{m_1 \cdot m_2}{(m_1 + m_2)} \right]g$$

**Case (C) :**

Here we shall consider the above case with a difference that ( $m_1$ ) placed on smooth inclined plane making an angle ( $\theta$ ) with horizontal as shown in fig. :

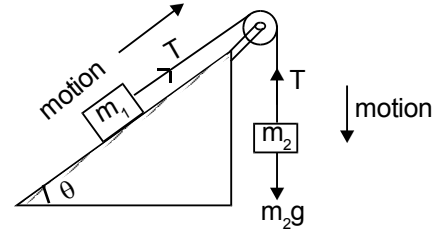

In this case

$$T - m_1g \sin \theta = m_1a$$

and

$$(m_2g - T) = m_2a$$

$$\text{solving we get, } a = \frac{(m_2 - m_1 \sin \theta)g}{(m_1 + m_2)}$$

and

$$T = m_2g - m_2a$$

$$\text{or } T = m_2g \left[ 1 - \frac{(m_2 - m_1 \sin \theta)}{(m_1 + m_2)} \right]$$

$$= \frac{m_1m_2g}{m_1 + m_2}(1 + \sin \theta)$$

**Case (D) :**

Let us consider the case when masses ( $m_1$ ) and ( $m_2$ ) are on inclined plane making angles ( $\alpha$ ) and ( $\beta$ ) with horizontal respectively as shown in figure :

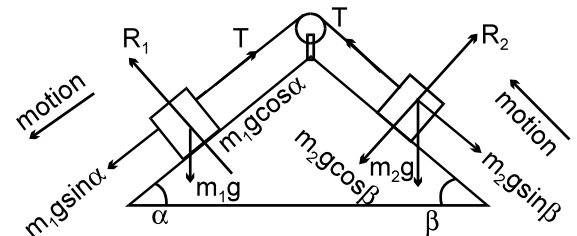

$$\text{We have, } m_1g \sin \alpha - T = m_1a$$

$$\text{and } T - m_2g \sin \beta = m_2a$$

solving these equations we get,

$$a = \frac{g(m_1 \sin \alpha - m_2 \sin \beta)}{(m_1 + m_2)}$$

and  $T = m_2 \frac{g(m_1 \sin \alpha - m_2 \sin \beta)}{(m_1 + m_2)} + m_2 g \sin \beta$

or  $T = \frac{m_1 m_2}{m_1 + m_2} (\sin \alpha + \sin \beta) g$

**Example based on Motion of Two Unlike Masses on Frictionless Pulley**

**Ex.29** The pulley arrangements of fig (a) and (b) are identical. The mass of the rope is negligible. In (a) the mass  $m$  is lifted up by attaching a mass  $2m$  to the other end of the rope. In (b)  $m$  is lifted up by pulling the other end of the rope with a constant downward force  $F = 2mg$  which is correct -

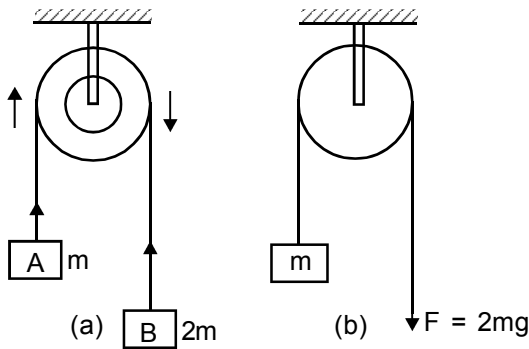

- (A) acceleration in case (b) is 3 times more than that in case (a)
- (B) In case (a) acceleration is  $g$ , while in case (b) it is  $2g$
- (C) In both the cases, acceleration is same
- (D) None of the above is correct

**Sol.(A)** In case (a), the pulling force  
 $= 2mg - mg = mg$   
 and the mass is  $2m + m = 3m$   
 so acceleration  $a = mg/3m = g/3$   
 While in case (b), the pulling force  
 $= 2mg - mg = mg$   
 but, the mass in motion is  
 $= m + 0 = m$   
 Acceleration  $a = mg/m = g$   
 Hence correct answer is (A)

**Example based on Motion of Three Unlike Mass on Frictionless Pulley**

**Ex.30** Three equal weights of mass  $m$  each are hanging on a string passing over a fixed pulley as shown in fig. The tensions in the string connecting weights A to B and B to C will respectively be -

- (A)  $\frac{2}{3} mg, \frac{2}{3} mg$
- (B)  $\frac{2}{3} mg, \frac{4}{3} mg$
- (C)  $\frac{4}{3} mg, \frac{2}{3} mg$
- (D)  $\frac{3}{2} mg, \frac{3}{4} mg$

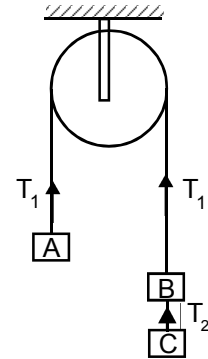

**Sol.(C)** If this problem as the pulling force is  $2mg$  while opposing force is  $mg$ , so net force  
 $F = 2mg - mg = mg$ ,  
 and as the mass in motion  
 $= m + m + m = 3m$

So the acceleration =  $\frac{\text{force}}{\text{mass}} = \frac{mg}{3m} = \frac{g}{3}$

Now as A is accelerated up while B and C down. so tension  $T_1$ , is such that

$$mg < T_1 < 2mg$$

Actually for the motion of A,

$$T_1 = m(g + a) = m(g + g/3) = \frac{4}{3} mg$$

Now to calculate tension in the string BC we consider the downward motion of C,

$$\text{i.e. } T_2 = m(g - a) = m(g - g/3) = \frac{2}{3} mg$$

Hence correct answer is (C)

**Example based on Motion of Two Unlike Masses on Frictionless Pulley**

**Ex.31** In the fig. shown, the velocity of each particle at the end of 4 sec will be -

- (A)  $0.872m/s$
- (B)  $8.72 m/s$
- (C)  $0.218m/s$
- (D)  $2.18m/s$

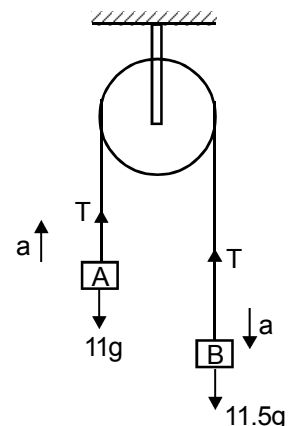

**Sol.(A)** As A moves up and B moves down with acceleration  $a$  for the motion of A ,

$$T - 11g = 11a \quad \dots (i)$$

for the motion of B,

$$11.5g - T = 11.5a \quad \dots(ii)$$

From (i) & (ii) ,

$$a = \frac{m_1 - m_2}{m_1 + m_2}$$

$$g = \frac{(11.5 - 11)9.8}{11.5 + 11} = 0.218 \text{ m/sec}^2$$

Assuming that the particles are initially at rest, their velocity at the end of 4 sec will be  $v = u + at = 0 + 0.218 \times 4 = 0.872 \text{ m/s}$

Hence correct answer is (A)

**Ex.32** In the above example, the height ascended or descended, as the case may be, during that time (i.e. 4 sec) will be -

- (A) 1.744 m                      (B) 17.44 m  
(C) 0.1744 m                    (D) none of these

**Sol.(A)** The height ascended by A in 4 sec

$$h = ut + \frac{1}{2}at^2 = 0 + \frac{1}{2}(0.218)4^2 = 1.744 \text{ m}$$

This is also the height descended by B in that time.

Hence correct answer is (A)

**Ex.33** In the **example 31**, if at the end of 4sec, the string be cut, the position of each particle in next 2 seconds will respectively be -

- (A) 17.856 m, 21.344 m  
(B) -21.344 m, 17.856 m  
(C) -17.856 m, 21.344 m  
(D) -17.856 m, -21.344 m

**Sol.(C)** At the end of 4 sec the string is cut. Now A and B are no longer connected bodies but become free ones, falling under gravity.

Velocity of A, when the string was cut = 0.872 m/s upwards.

Acceleration  $a = -g$  (acting downwards), displacement from this position in the subsequent 2 sec

$$h = ut + \frac{1}{2}at^2 = (0.872) \times 2 + \frac{1}{2}(-9.8)2^2 = 1.744 - 4.9 \times 4 = -17.856 \text{ m}$$

A descends down by a distance of 17.856 m from the position it occupied at the end of 4 sec from its start. B has a free fall. Its position is given by

$$S = ut + \frac{1}{2}at^2 = 0.872 \times 2 + \frac{1}{2} \times 9.8 \times 4 = 21.344 \text{ m}$$

Below the position it occupied when the string was cut.

Hence correct answer is (C)

**Example based on Motion of Masses Hanging from a Pulley, Lying on Horizontal Table.**

**Ex.34** Consider the situation shown in figure. Both the pulleys and the strings are light and all the surfaces are frictionless. The acceleration of mass M, tension in the string PQ and force exerted by the clamp on the pulley, will respectively be -

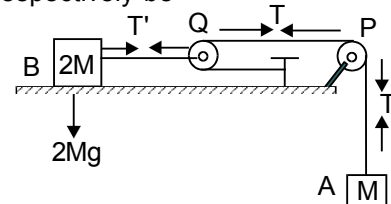

(A)  $(2/3)g, (1/3)Mg, (\sqrt{2}/3)Mg$

(B)  $(1/3)g, (1/3)Mg, (\sqrt{2}/3)Mg$

(C)  $(1/3)g, (2/3)Mg, \sqrt{3} Mg$

(D)  $2g, (1/2)g, \sqrt{2} Mg$

**Sol.(A)** As pulley Q is not fixed so if it moves a distance  $d$  the length of string between P and Q will change by  $2d$  ( $d$  from above and  $d$  from below) i.e. M will move  $2d$ .

This in turn implies that if  $a$  ( $\rightarrow 2d$ ) is the acceleration of M, the acceleration of Q and so  $2M$  will be of  $(a/2)$

Now if we consider the motion of mass M, it is accelerated down so

$$T = M(g - a) \quad \dots(1)$$

And for the motion of Q,

$$2T - T' = 0 \times (a/2) = 0$$

$$\Rightarrow T' = 2T \quad \dots(2)$$

And for the motion of mass  $2M$ ,

$$T' = 2M(a/2)$$

$$\Rightarrow T' = Ma \quad \dots(3)$$

From equation (2) and (3)  $T = \frac{1}{2}Ma$ , so equation (1) reduces

$$\left(\frac{1}{2}\right)Ma = M(g - a)$$

$$\Rightarrow a = \frac{2}{3}g$$

So the acceleration of mass M is  $(2/3)g$  while tension in the string PQ from eq.(1) will be  $T = M(g - (2/3)g) = (1/3)Mg$   
The force exerted by clamp on the pulley

$$= \sqrt{T^2 + T^2} = \frac{\sqrt{2}}{3} Mg$$

Hence correct answer is (A)

Examples based on

### Motion of Masses Hanging from a Pulley, Lying on an Inclined Plane

**Ex.35** A body of mass 50kg resting on a smooth inclined plane is connected by a massless inextensible string passing over a smooth pulley at the top of the inclined plane to another mass 40 kg having as shown. The distance through which 50 kg mass fall in 4 sec will be - (The angle of the inclined plane is  $30^\circ$ )

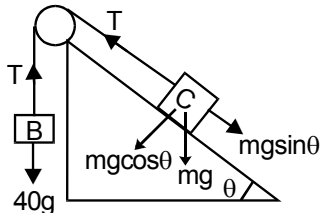

- (A) 13.04 m                      (B) 1.63m  
(C) 1.304 m                      (D) 16.3m

**Sol.(A)** The tension is same in two segments

For B the equation is  
 $(40 \times 9.8 - T) = 40a$  ... (1)

For C the equation is  
 $(T - 50 \times 9.8 \times \frac{1}{2}) = 50a$  ... (2)

From equation (1) and (2)  $a = 1.63 \text{ m/s}^2$   
distance of fall

$$S = \frac{1}{2} at^2 = \frac{1}{2} \times 1.63 \times 4^2 = 13.04 \text{ m}$$

Hence correct answer is (A)

**Ex.36** Two bodies of mass 30kg and 20kg are connected by a massless inextensible string passing over a frictionless pulley fixed at the top of a wedge having smooth surface. The tension in the string is -

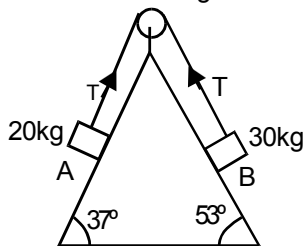

- (A) 40.70 N                      (B) 164.64 N  
(C) 1.22 N                      (D) 4.07 N

**Sol.(B)** The string is massless and inextensible the tension T is same. Let mass B move down the inclined plane. For B the equation of motion  $m_1 g \sin \theta - T = m_1 a$   
 $30 \times 9.8 \times \sin 53^\circ - T = 30a$   
 $\Rightarrow 235.2 - T = 30a$  ... (1)

and for A the equation of motion  
 $T - 20 \times 9.8 \times \sin 37^\circ = 20a$   
 $T - 117.6 = 20a$  ... (2)

From (1) & (2)  $T = 164.64 \text{ N}$

Hence correct answer is (B)

### POINTS TO REMEMBER

1. Newton's 1<sup>st</sup> Law of motion states that every body has tendency to oppose any change in its state of motion.

This property of objects is called Inertia.

2. Inertia is of three types (i) Inertia of rest (ii) Inertia of motion and (iii) Inertia of direction.

3. Inertia  $\propto$  mass

4. Linear momentum  $\vec{p} = m \vec{v}$

5. Newton's 2<sup>nd</sup> law of motion states that rate of change of momentum is equal to applied force.

$$\vec{F} = \frac{\Delta \vec{p}}{\Delta t} = m \vec{a}$$

$$1 \text{ Newton} = 10^5 \text{ dyne}$$

6. Newton's 1<sup>st</sup> and 3<sup>rd</sup> law can be derived from second law therefore 2<sup>nd</sup> law is the most fundamental law out of the three law.

7. Impulse =  $\vec{F} \Delta t = \Delta \vec{p} = (\vec{p}_1 - \vec{p}_2)$

8. According to law of conservation of linear momentum :

Initial Momentum = Final Momentum

$$m_1 u_1 + m_2 u_2 = m_1 v_1 + m_2 v_2$$

9. Thrust on rocket

$$\vec{F} = \frac{\Delta M}{\Delta t} \vec{v} - M \vec{g}$$

or 
$$\vec{F} = \frac{\Delta M}{\Delta t} \cdot \vec{v}$$

according as gravity is present or absent.

**10. Acceleration of rocket**

$$\vec{a} = \frac{\Delta M}{\Delta t} \cdot \frac{\vec{v}}{M} - \vec{g}$$

or

$$\vec{a} = \frac{\Delta M}{\Delta t} \cdot \frac{\vec{v}}{M}$$

according as gravity is present or absent.

**11. For equilibrium of a body under the action of concurrent forces**

$$\vec{F}_1 + \vec{F}_2 + \vec{F}_3 + \dots + \vec{F}_n = 0$$

**12.** Apparent weight of a body in the lift accelerated up is  $W = m (g + a)$ .

**13.** Apparent weight of a body in the lift accelerated down is  $W = m (g - a)$

**14.** If the downward acceleration of the lift is  $a = g$ , then

$W = 0$  i.e. the body will enjoy weightlessness.

**15.** If the downward acceleration of the body is  $a > g$ , then  $W$  is negative, the body will rise up to the ceiling of lift